



HEXAPODS

AQUILON



Applications

- Motion simulator
- High payload positioner
- Vehicle simulator
- Swell simulator

Specifications

- Payload capacity 6 tons
- Linear travel range ± 800 mm
- Angular travel range $\pm 40^\circ$



AQUILON is the most powerful hexapod of our range. It provides motion of very high payloads following the 6 degrees of freedom (6 DOF: $T_x, T_y, T_z, R_x, R_y, R_z$).

Remarkable payload capacities

The robust mechanical structure of AQUILON combined with a powerful electrical motorisation allows the hexapod to move payloads up to 6 tons on important linear and angular travel ranges.

Outstanding dynamic performances

The configuration and the performances of the actuators enable AQUILON to realize outstanding dynamic motions.

Speed: 1.6 m/s ; acceleration: 7 m/s².

Ergonomic and user-friendly control software

The control of the mobile platform is done intuitively through an ergonomic graphical interface that allows the operator to save time in learning and implementing the system. The control software allows to reproduce the movements generated by the motion designer software.

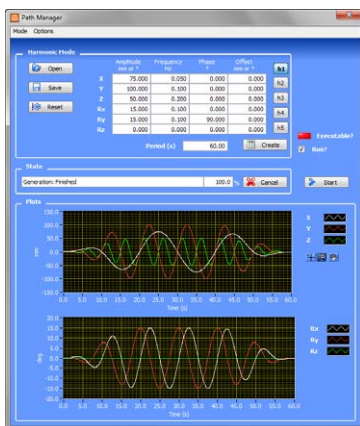

Control software

Axis	Travel range ⁽¹⁾ for payloads < 3.5 T	Travel range ⁽¹⁾ for 3.5 T < payloads < 6 T	Speeds	Accelerations
Linear travel Tx	± 800 mm	± 600 mm	± 1 800 mm/s	7 000 mm/s ²
Linear travel Ty	± 800 mm	± 600 mm	± 1 800 mm/s	7 000 mm/s ²
Linear travel Tz	± 650 mm	± 650 mm	± 1 600 mm/s	7 000 mm/s ²
Angular travel Rx	± 40 °	± 28 °	± 200 °/s	1 200 °/s ²
Angular travel Ry	± 40 °	± 28 °	± 200 °/s	1 200 °/s ²
Angular travel Rz	± 40 °	± 35 °	± 100 °/s	600 °/s ²

(1) The performances specified are for single axis motions, with all other axes at midrange and for a rotation centre defined centred on the top of the upper platform.

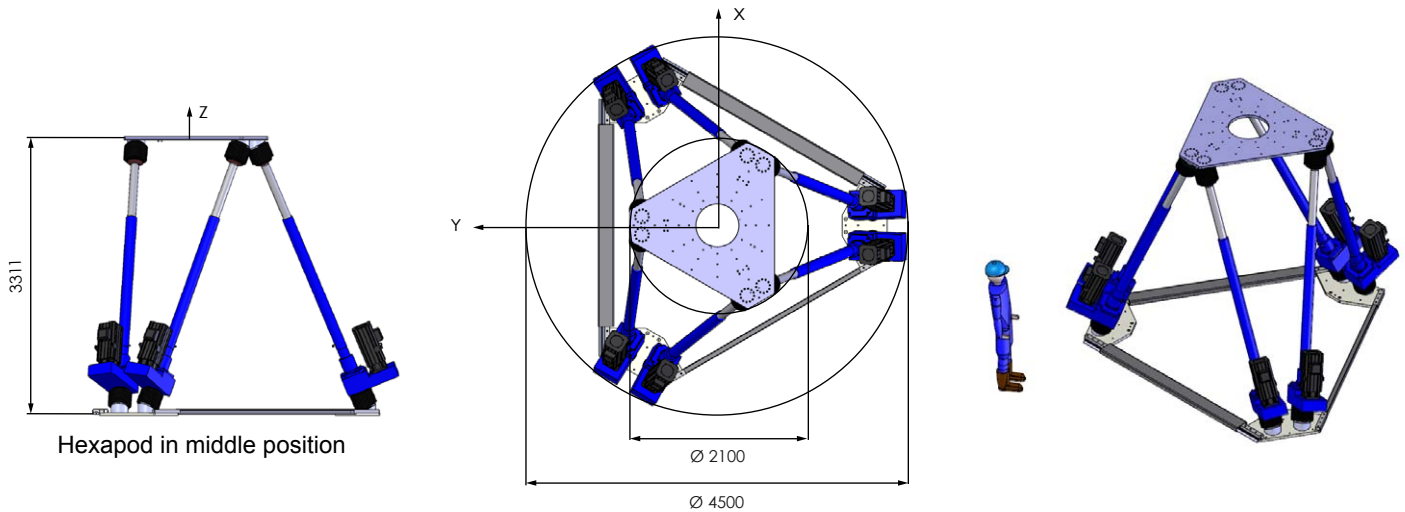

HEXAPOD

Payload capacity	6 000 kg
Size of the mobile platform	Ø 2 100 mm
Height in middle position	3 311 mm
Weight	3 000 kg

CONTROL

Electronic cabinet dimensions (W x H x D)	2 200 x 4 000 x 600 mm
Interface	Ethernet
Power supply	400 V AC (three-phase) 630 A (250 kW)

AQUILON

Your specifications are particular, do not hesitate to consult us!

AQUILON's options

- IP54 motor protection
- ATEX compatibility
- Acquisition and storage of motions
- Customized platform design