



# NanoPos hexapod

Nanometer resolution miniature hexapod



## KEY FEATURES

- Payload capacity up to 500 g
- Linear resolution 10 nm
- Angular resolution 1  $\mu$ rad
- Height in middle position 68 mm



## APPLICATIONS

- Instrumentation
- Optics
- Testing laboratories
- Semiconductors
- Synchrotrons
- Microscopy
- Nanotechnologies



*NanoPos hexapod is positioning a sample on ID11 new Nanoscope station of ESRF synchrotron. ID11 is a beamline dedicated to moderate to high energy diffraction and/or imaging studies of a variety of systems of interest for their physical, mechanical, or chemical properties.*

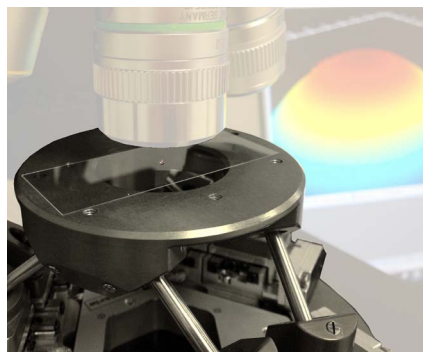

*NanoPos is positioning a sample under a microscope with a nanometric resolution for surface measurements.*

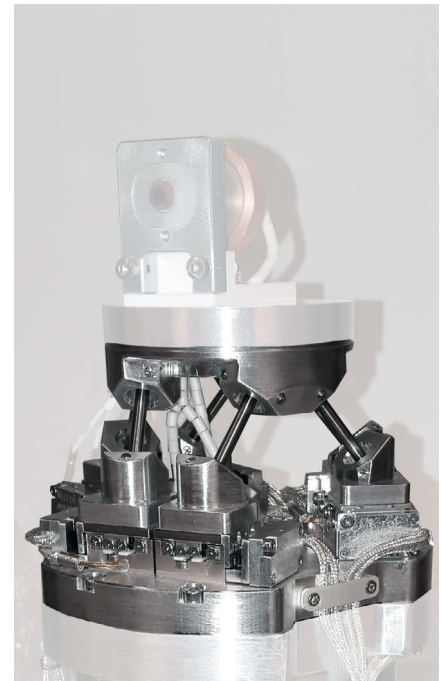

*A UHV compatible NanoPos is positioning a sample in a 10<sup>-9</sup> mbar chamber for experiments at the University of Stockholm.*

NanoPos	
<b>Motion and positioning</b>	
Travel range Tx, Ty (mm)	± 5
Travel range Tz (mm)	± 4
Travel range Rx, Ry (deg)	± 7
Travel range Rz (deg)	± 10
Resolution Tx, Ty, Tz (nm)	10
Resolution Rx, Ry, Rz (μrad)	1
Repeatability Tx, Ty, Tz (nm)	± 38
Repeatability Rx, Ry, Rz (μrad)	± 1
Speed (mm/s; deg/s)	1; 1
<b>Mechanical properties</b>	
Payload capacity (g) (vertical orientation)	500
Motor type	Piezo motor
<b>Miscellaneous</b>	
Operating temperature range (°C)	+ 5 to + 40
Materials	Aluminum, invar, ceramic, stainless steel
Size mobile platform (mm)	Ø 72
Central aperture (mm)	Ø 32
Height in middle position (mm)	68
Mass (g)	505
Cable length (m)	1.2
Options	<ul style="list-style-type: none"> <li>Customized platform design</li> <li>Larger travel range</li> <li>Scalable size</li> <li>Vacuum compatibility</li> <li>Non magnetic</li> </ul>
<b>Controller</b>	
Controller type	CAPELLA
Interface	Ethernet, USB, Serial (RS-232)
Power supply	110-240 VAC / 50-60 Hz

Datasheet subject to change without notice. All data are superseded by any new release. R1909005

The performances are specified for single axis motions, with all other axes at midrange and for a rotation center in the middle of the mobile platform.

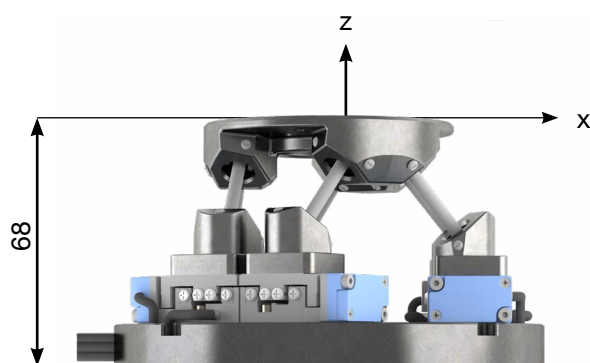

Hexapod in middle position

